

● DESIGN | ● BUILD | ● SUPPLY



Segue 790

Standard unit may not be exactly as shown.

Segue is a proud member of the Supreme International family of products. Locate your nearest dealer at: www.seguetmr.com



Segue 790

Standard Equipment

- Patented Freestanding Vertical Mixing Auger
- Manual Restrictor Plates
- Heavy-Duty Planetary Drive
- Replaceable Forage Cutting Blades (4)
- 540 rpm PTO
- Heavy-Duty Tubular Steel Frame
- 5/8" M/S Floor
- 1/4" M/S Walls
- 5/8" M/S Lower Auger Flighting
- Left or Right Hand Side Door With Drop Chute
- 3 pt DG Stad 02 Scale with Remote Port and 12 Recipe Programming Capability
- 12 Volt Battery
- Removable Hitch Jack
- AR200 Kicker Plate
- (2) 12.5L-15, 12 Ply Rated Hwy Service Tires

Model 790 Pull-Type

	Imperial	Metric
Max. Payload At 5mph / 8km/h	6,000 lbs.	2,727 kg
Overall Width	97 in.	246 cm
Overall Length	170 in.	432 cm
Min. HP Req.	50	50
Capacity W/10" Extension	278 cu. ft.	7.9 m ³
Capacity Struck Level	235 cu. ft.	6.7 m ³

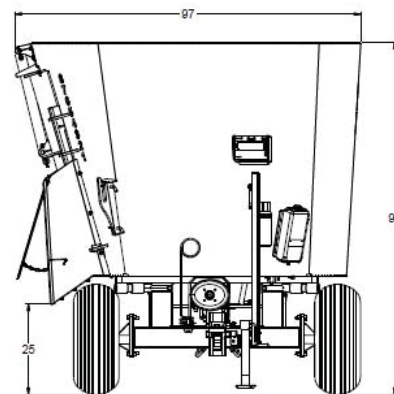
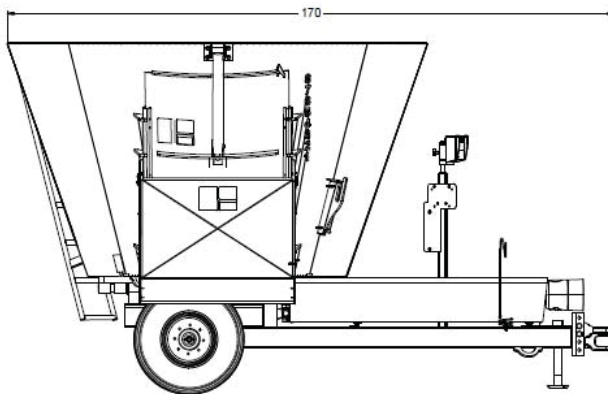

Locate your nearest dealer at:
www.seguetmr.com